

Heatless Crimp Splices



INTRODUCTION

Carlisle Interconnect Technologies' (CarlisleIT) Tri-Star Electronics has been a provider of the broadest selection of high reliability contacts for more than 35 years, and now we are revolutionizing the industry with our new Heatless Crimp Splice.

Our Heatless Crimp Splices are manufactured to give you high quality performance in the harshest operating environments, while reducing downtime with quick and easy installation with its positive locking insulator assembly. Since there is no heat required to install, the new Heatless Crimp Splice will save considerable labor hours as flammable fuels no longer need to be purged prior to repair — and no special tools are needed!

CarlisleIT's Heatless Crimp Splice is needed wherever maintenance is required on, or near, flammable liquids to achieve a superior seal. This product can be expanded beyond just military and commercial aircraft applications to oil & gas exploration and refineries, heavy equipment, industrial machinery, marine vessels and military ground vehicles.

PERFORMANCE BENEFITS

- » Meets or exceeds all applicable performance requirements of AS81824/14
- » No heat requirement to install and create a seal
- » Uses proven material and technologies
- » Uses the same M22520 crimp tools as AS81824/1
- » Easy and quick installation

ENVIRONMENTAL BENEFITS

- » Operational Temperature Rating of 175°C
- » Insulation Resistance MIL-STD-202, Method 302 Cond B (500V)
- » DWV per MIL-STD-202, Method 301 (2500V)
- » Altitude Immersion 75,000 ft (26.78mm of Hg)
- » Fluid immersion tested – MIL-PRF-7808, -23699, -5606, -87937, MIL-DTL-5624, -83133, & AMS 1424
- » Vibration MIL-STD-202, Method 201

CRIMP TOOL CHART

Military Designation	Part Number	AWG Range		Crimp Tool	Crimp Die
		Size	Diameter		
AS81824/14-1	H-C2015N	20, 22, 24, 26	.080 - .036	M22520/5-01 or M22520/37-01 (Tool Set)	M22520/5-103
AS81824/14-2	H-C1615N	16, 18	.106 - .058		M22520/5-102
AS81824/14-3	H-C1215N	12, 14	.153 - .078		



Heatless Crimp Splices

HEATLESS CRIMP SPLICE DESIGN

Metal Crimp Barrel

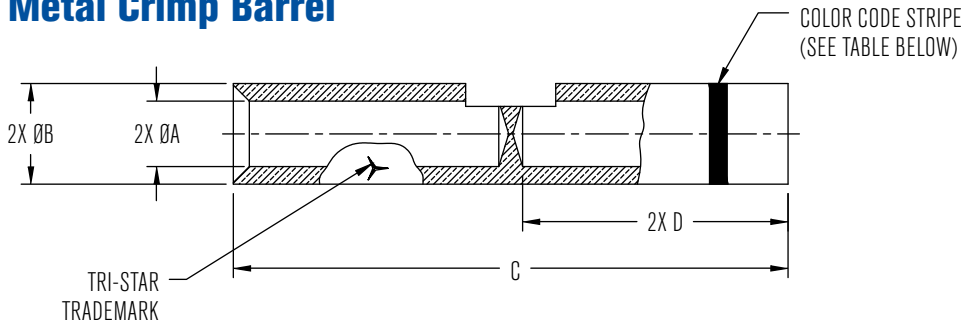

Heatless Sealed Insulator Assembly

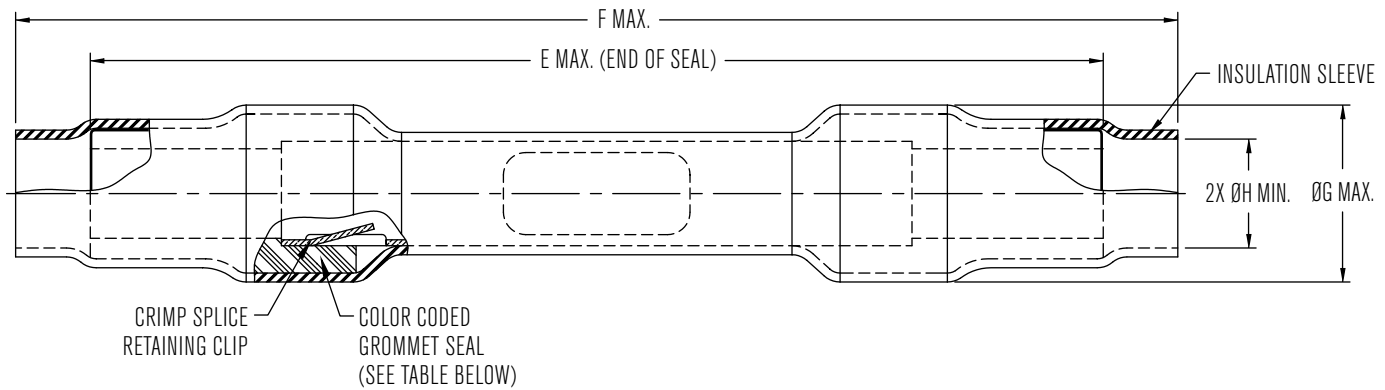

Military Designation	Part Number	AWG Range	ØA	ØB	C	D	E Max.	F Max.	ØG Max.	ØH Min.	Color Code
AS81824/14-1*	H-C2015N	20, 22, 24, 26	.050 (1.27) .045 (1.14)	.080 (2.03) .075 (1.91)	.510 (12.95) .490 (12.45)	.245 (6.22) .225 (5.71)	1.230 (31.24)	1.450 (36.83)	.22 (5.59)	.085 (2.16)	Red
AS81824/14-2*	H-C1615N	16, 18	.069 (1.75) .064 (1.63)	.106 (2.70) .101 (2.57)	.585 (14.86)	.280 (7.11)	1.400 (35.56)	1.622 (41.20)	.26 (6.60)	.116 (2.95)	Blue
AS81824/14-3*	H-C1215N	12, 14	.102 (2.59) .097 (2.46)	.153 (3.89) .147 (3.73)	.565 (14.35)	.260 (6.60)	1.535 (38.99)	1.750 (44.45)	.32 (8.13)	.164 (4.17)	Yellow

* AS81824 provided for reference only.

